

Electromechanical Creep Testing Machines IB-CREEP Series

▶ Capacity: 10 - 200 kN



S.A.E. IBERTEST

Since 1970
Made in Spain (EU)

www.iberfied.com



Introduction

Electromechanical machine especially designed for creep testing, relaxation, low fatigue, etc. According to: ISO 204, ASTM E139, ASTM E606/E606M-12, ISO 12106.

New optimised design of our IB-CREEP series which leads our machines a big step beyond, placing them as one of the most advanced Creep testing machines in the world.

- › **Always forward.** Fully renovated Furnace.
- › **Powerful and intuitive.** New advanced furnace control system.
- › **Higher efficiency.** Improved energy efficiency of the machine.
- › **Robust and reliable.** Increased stiffness of the entire system.
- › **Save space and intelligent design.** Integration of electronics into the machine frame.
- › **Easy adjustment of Setpoints.**

Application

New IB-CREEP series provide you a wide range of testing possibilities into the branch of Creep tests.

- › Creep tests.
- › Relaxation tests.
- › Creep rupture tests.
- › Creep crack tests.
- › Long-term tests.
- › Low cycle fatigue tests (LCF).
- › Ask for other specific test.

NEW: ALL in One touch PC interface

New user interface, with embedded touch screen PC, modern, user-friendly and with improved performances.

An alternative to conventional table top PC's, placing together a compact design with touch screen, with all the performances of other systems.

This system is directly fitted to testing frame with an orientable support, reducing space requirements and offers an ergonomic working position for machine operation as well as for testing devices management.



IB-CREEP 30. Maximum Capacity 30 kN.

Creep Testing.

The "Creep Test" is performed on a specimen. In simple terms, the specimen is heated up to a temperature between 300°C and 1200°C depending on material. Once the temperature set-point is reached, a constant load is applied to exert a longitudinal force on the grain structure of the material. The load is maintained for the period of the test or until the specimen ruptures. During the test, data is continuously monitored and recorded to qualify the stability of the temperatures, load and specimen elongation.

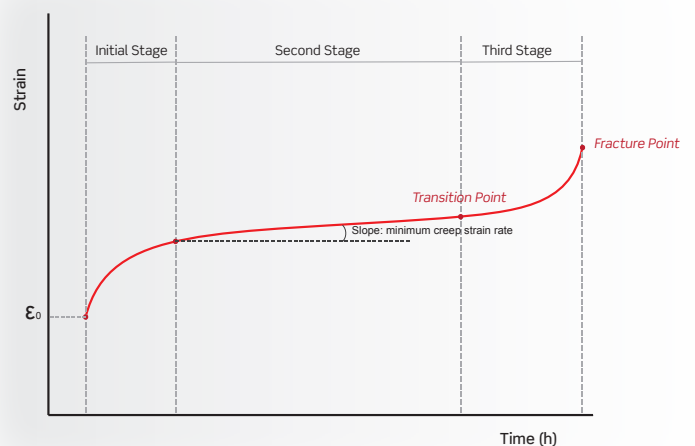

Technical specifications for IB-CREEP 10 - 200

SERIE	IB-CREEP					
Maximum load	10 kN	20 kN	30 kN	50 kN	100 kN	200 kN
Load measurement	Universal strain-gage load cell (tension-compression).					
Load cell Repeatability	Better or equal to $\pm 0.05\%$					
Measuring Range	1 % to 100 % of the load cell nominal capacity (autoescale)					
Class	0.5 according to ISO 7500 - Meets ASTM E-4					
Strength Resolution	5 dígits with floating coma					
Number of Guiding columns	2					
Screw drivers	1 high precision ball screw drivers with scrapers					
Displacement speed range	Between 0,001 and 100,00 mm/min (Other speed are possible request)					
Displacement measurement	Encoder					
Displacement resolution	5 dígits (3 integers and 2 decimals) : $\pm 0,001$ mm					
Power supply	Three-phase 380 V plus neutral and earth, 50/60 Hz (to specify)					
Power consumption without furnace	≤ 750 W	≤ 500 W	≤ 500 W	≤ 750 W	≤ 750 W	≤ 1500 W
Emergency stop	" Mushroom " type, placed on the testing frame					

IBERTEST reserves the right to modify the specifications described without prior notice.

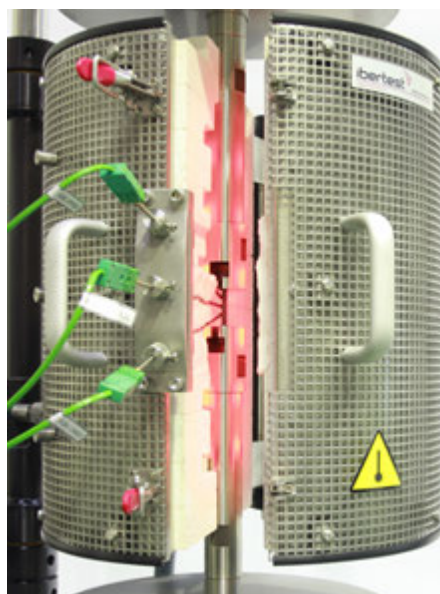

Performing the creep test



Typical steel specimen for creep test



Specimen before and after test

New Furnace

The fully renovated furnace for CREEP testing machines together with its control system setting up one of the most advanced furnace for high temperature tests worldwide.

Temperature control and regulation system that assure an homogeneous and steady temperature applied on the sample with temperature variation control $< 0,5^{\circ}\text{C}$.

- High temperature furnace.
- Working temperature: 300 to 1200 °C.
- High Stability during long-term tests.
- Length of controlled temperature zone: 300 mm.
- Temperature Gradient $< 3^{\circ}\text{C}$.
- External temperature of the furnace $< 50^{\circ}\text{C}$.
- Internal dimensions: 70 mm diameter x 340 mm length.
- External dimensions: 320 mm diameter x 410 mm length.
- Temperature measurement: through 3 Thermocouples directly over the sample.
- 1 thermocouple for safety system.
- Isolated thermocouples inputs.
- Intelligent temperature control and recording system.
- Temperature limits with visual and sound alarms.
- Allows autonomous temperature control.

New control system for IB-CREEP developed by IBERTEST

- Based in ramp programmers for temperature scales.
- Control over: temperature/time
- Adjustable PID
- Control unit based on PLC with integrated touchscreen
- 10.4", 16 bit 65,000-Color Touchscreen, Resolution 800 x 600 (SVGA) TFT display
- White LED illuminated screen
- I/O Expansion Module Adapter, Isolated
- I/O Expansion Module 8 Analog/Thermocouple Inputs
- I/O Expansion Modules 8 Inputs, 8 Outputs



IB-CREEP High temperature furnace



IB-CREEP upper crosshead with spherical bearing and new furnace.



Furnace articulated support

Furnace, New Control Features

New control Features of furnace including a powerful PLC with a built-in HMI Operator Panel comprising a 10.4" color touch-screen for visualizes and control furnace temperature. Independent graphics of each heating zone and thermocouple. Easy and quick configuration of setting points temperatures.

Other features:

- › Possibilities of Cellular Communication- SMS, GPRS (on request)
- › Possibility of Web Server, to visualize and control via web or intranet. (on request)
- › Upgradeable firmware, Alarms, & Multilanguage Support.



Testing Screen, rest state



Testing Screen, 3 zones heating



Easy and fast PID configuration

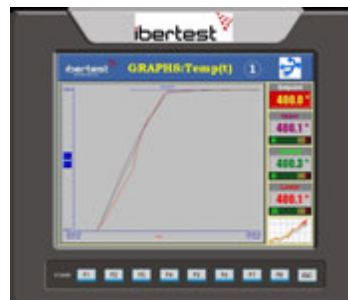

Full on-screen Temperature curve



Zoom function on temperature curve for more details



Possibility to enable and disable heating zones or thermocouples during test

Pull Rods and Adapters

The fixing of specimens is very important in order to have an accurate determination of material properties. During CREEP tests, very high temperatures are reached, therefore it is necessary that elements that hold the specimen are thermally stable and enough resistance.

For this reason SAE IBERTEST made its poll rods and adapters of superalloys such as INCONEL, Hastelloy, SERATHERM, etc.

Shoulder-headed specimens*



Spherical bearing

The upper pull rod is joined to a spherical bearing in order to assure the application of perfectly axial loads.



Threaded head specimens*



Clevis couplings - Flat specimen*



* SAE IBERTEST manufactures pull rods and adapters for specimens according to main standards from EN, ASTM, ISO, GOST, etc.

Load Cell

- › Symmetrical Design
- › Electronic, Plug and Play™-Type (Calibration and technical data are saved in sensor plug)
- › High accuracy (Linearity, Repeatability, Resolution) acc. to ASTM E 4 and ISO 7500-1
- › High measurement range in class 1 acc. to ISO 7500-1 from 0.5 %100% of nominal load



AlignTest (optional)

- › Optional alignment device
- › Precise axial alignment.
- › Optional axial alignment calibration according to ASTM E 292 and NADCAP requirements.

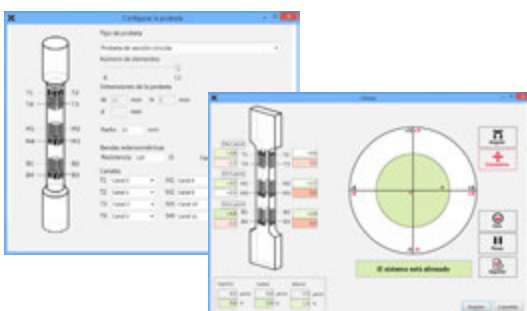

Machine

SERIE	IB-CREEP					
Version	10 kN	20 kN	30 kN	50 kN	100 kN	200 kN
Height (A)		2350 mm		2425 mm		2600 mm
Width (B)		710 mm		750 mm		750 mm
Depth (C)		540 mm		600 mm		600 mm
Dist. between columns (D)		500 mm		500 mm		500 mm
Maximum travel (E)		180 mm		180 mm		180 mm

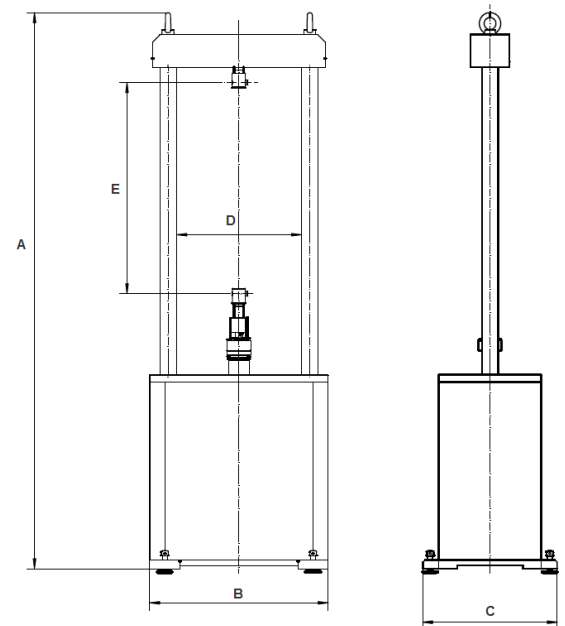

Furnace

SERIE	IB-TRX3-12
Maximum working temperature:	1200 °C
Maximum working temperature for continuous works:	1000 °C
Accuracy:	±1°C
Fluctuation of temperature control:	±2°C
Homogeneity in 100 mm:	±5°C
Independent heating zones	3 (100 - 100 - 100 mm)
Internal dimension (height):	300 mm
Exterior dimensions:	410 mm (height) x 320 mm (diameter)
Junction box dimensions:	240 mm (height) x 80 mm (width) x 50 mm (depth)
Upper hole diameter:	70 mm
Lower hole diameter:	40 mm
Inner hole diameter:	90 mm
Power:	1.95 kW
Power supply:	Three Phase 400 V + N+ G. 50/60 Hz

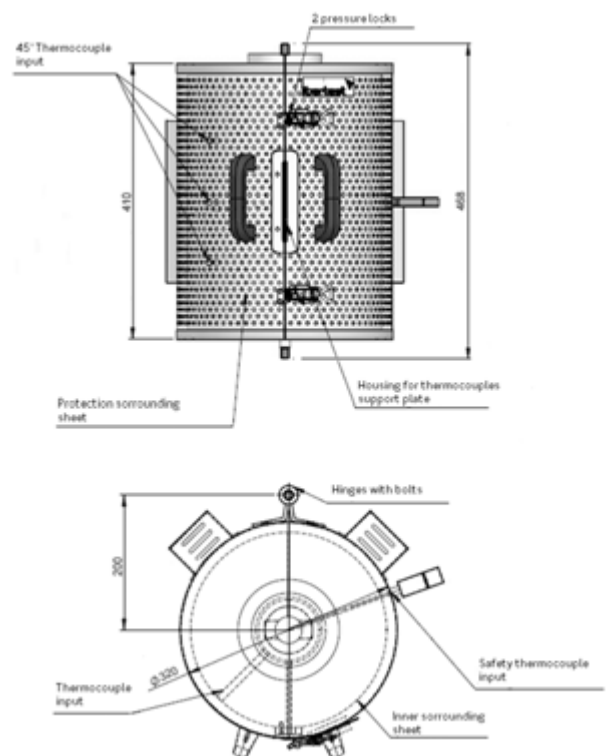

MD CONTROL UNITS . MODULAR SYSTEM

Electronic controller units MD are specially designed for data acquisition and close loop control of testing instruments.

Measuring transducers are plugged to the MD module and the measurement is exported to the computer via USB or Ethernet.

The IBERTEST software WinTest32 makes data collection and shows real-time for drawing graphs and test results calculation.

This new system, based in external modules, substitutes the old electronic cards mounted into the computer, improving the performance, reliability and data acquisition speed.

Due to the external module configuration, the computer can be fast and easily changed by any other suitable PC or laptop, without need to make adjustments or calibrations.

This is very useful in case of eventual breakdown of the computer, or when obsolete computer needs to be changed.



MD2 unit, with safety box, to be placed into the frame or the electrical panel of the machine



MD2 module, side view



MD2 module, rear view

MD2 MODULAR CONTROL UNIT, FOR STATIC TESTS

MD2 unit has been designed for **static** machines.

The MD2 can be used either in electromechanical or servohydraulic machines.

The MD2 unit has the following input channels:

- Load channel. With a resolution of ± 180.000 steps. For the connection of a load cell or pressure transducer.
- X-Head position channel. For connecting a digital incremental position transducer (encoder) or a resolver (encoder emulator) or position transducers (SSI, draw wire linear transducers, etc.)
- 2 Bus extension slots for data acquisition cards "plug-in" type, for connection of further load cells, extensometers, LVDTs, position transducers, etc.

The MD2 unit comprises an analogical $\pm 10V$ drive channel for a servovalve (hydraulic machines) or a servomotor (electromechanical machines).

MD2 features a high quality build-in electrical safety box, dustproof, ensuring the perfect state of the internal electronics.

This compact box allows to integrate the module within the frame of the machine itself (TESTCOM model) or within the electric panel of the machine (machines EUROTTEST, IBMT4, UMIB, IBMU4).

Data acquisition card with "plug-in" connection to the expansion slots of the modules MD

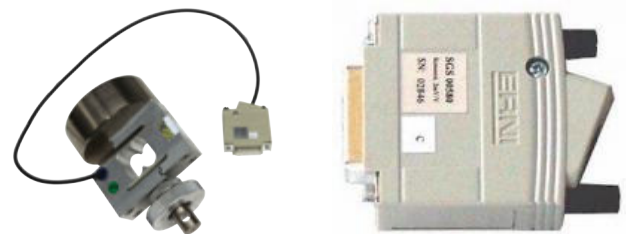
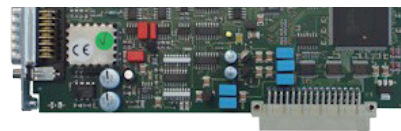

500 N load cell, S shaped, universal type (tension / compression). Connector with EEPROM memory chip is also showed

The transducers comprises connector-plugs with built-chip EEPROM memory.

The transducer calibration data (unit of measure, range, zero position, linearization, etc.) are stored in the EEPROM memory. Thus, the transducer is automatically recognized as input channel when plugged to the by MD

PID CONTROL

The MD module uses PID (proportional-integral-derivative) for control loop feedback of the application of force to the test specimen.

The PID controller calculates an error value as the difference between the measured process variable (force, position or strain) and the desired setpoint.

The three signals coming from the PID are combined to generate a new command signal, which is sent to the servovalve or servomotor to eliminate the deviation as fast as possible and assuring the stability of the process.

The process of detection, evaluation and new signal generation is repeated again and again. The time consumed is the **closed loop control** time and the lower the time, the faster the controller.

3 CONTROL OPTIONS

MD electronics allows to close the control loop with the applied load (control in kN/s) or with the position (control in mm/s) or with the material deformation (control in mm/s):

1. Load control

The MD module receives the signal from the load cell and compares this feedback value with the command value (N/s or kN/s).

2. Position control

The MD module receives the signal from machine's position transducer (encoder, resolver, LVDT, etc.) and compares this feedback value with the command value (mm/min).

3. Strain control

The MD module receives the signal from machine's deformation transducer (extensometer) and compares this feedback value with the command value (mm/s or mm/min)

Applications of each type of control

Load control is normally used on low load resistance tests materials which undergo deformation just before fracture, such as concrete, cement, ceramics, rocks, adhesives, etc. as well as in metals test on material elastic zone.

Position control is used in materials with high deformation, as rubers, elastomers, etc as well as on metals after elastic range.

Strain control is used in fracture tests and for research applications.

Automatic and programmable control change.

The IBERTEST WinTest32 testing software allows to define several criteria for changing control automatically (defined variation in the slope of the graphic, certain value of strength, load, position or deformation).

This feature is used in several applications as in metals testing, to allow the control change among behaviour regions of the material (change from elastic to plastic behaviour)

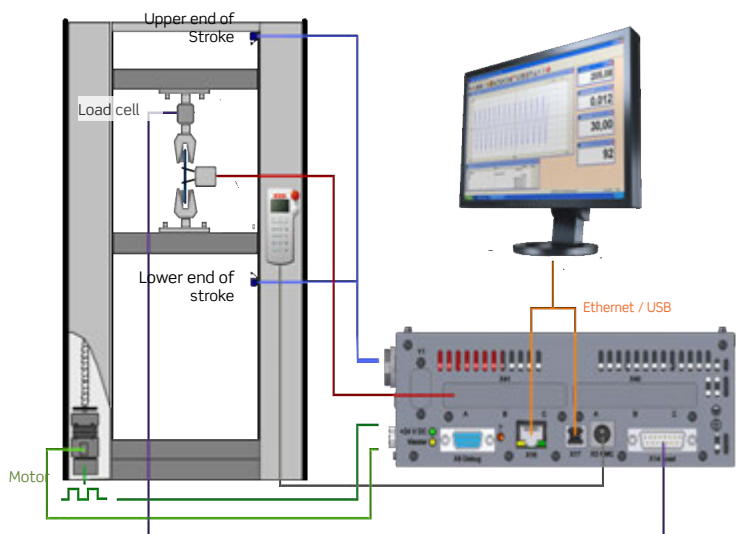

Scheme of load control for electromechanical testing machines







Built-in MD2 module in a Testcom machine



Remote control unit UCRD-6 (Optional)

Specifications of MD2 and MD22 modules, for static and dynamic tests

MODULE	MD2	MD22
Front View		
Rear View		
Application purposes	Static tests	
Microprocessor	CPU 800 MHz	
Channels	Up to 4	
Resolution	± 180.000 steps per channel	
Max sampling frequency	1 kHz 1000 reading per sec per channel	
Sincronization	All channels fully synchronous and simultaneous	
Closing loop time	1 milisecond (1000 times per second)	
Drive interface	$\pm 10V$ -Command-Output (generated with ± 15 Bit resolution) I/O's and relays for safety functions	
Expansion possibilities	Up to 8 modules can be connected. 32 total synchronous channels	
PC communication	USB 2.0 full speed and/or Ethernet 10 / 100 Mbit	
Digital Inputs (24 V)	8	
Digital outputs (24 V)	8	
Serial sensor interface	COM1 (internal)	
Debug interface	COM2: 115 kB	
Slot for safety shield	YES	
Power supply	DC 24 V	
Remote control option	YES	NO

"TECHNICAL SUPPORT HAS NEVER BEEN EASIER"

TELEDIAGNOSIS is a remote diagnostic service and maintenance support, available for all IBERTEST equipment and testing machines equipped with data acquisition system by computer.

The immediate attention of TELEDIAGNOSIS service for customers located worldwide, minimizes downtimes and avoids delays in the work of laboratory, while reducing or eliminating the overhead of moving the IBERTEST technicians.

To run TELEDIAGNOSIS a link program is used which establishes a remote connection to control the computer of the machine, quick and safe, ensuring IBERTEST services even at facilities with distant locations.

Thereby, an easy and effective intervention from our Technical Service is possible regardless of the location of the machine, as long as an access to INTERNET is available.

Even on those occasions when the Technical Service must act "in situ", the TELEDIAGNOSIS is helpful to clearly identify the problem in advance and improve first-visit resolution rates.

During a TELEDIAGNOSIS session, the following actions can be performed:

- › **Software revision and correction.** IBERTEST technicians can inspect the software file system, looking for wrong configurations, lost files and directories, corrupted files, viruses or others. Once the errors are detected, only the appropriate libraries and changes are transferred, without reinstalling complete programs.
- › **Remote handling.** IBERTEST technicians can operate the remote machine in real time to perform maneuvers, tests of mechanical movement, installation of testing transducers and accessories, verification of electrical and electronic systems, on/off alarm and security systems, etc.
- › **Videoconference.** Through webcam a videoconference between client and our technicians can be maintained, thus we can get visual-information about the correct operation of the machine's mechanical and hydraulic systems. Also, by written or voice messages, it is possible to exchange views and comments, and give appropriate instructions to the user, when necessary, to perform some physical action in the machine.
- › **Updates.** The software can be easily updated to its latest version, which allows enjoying the advantages resulting from the continuing work of review and program development.
- › **Factory reset.** All machines have a backup, stored in our servers in Madrid, which allows you to restore the original configurations when necessary.

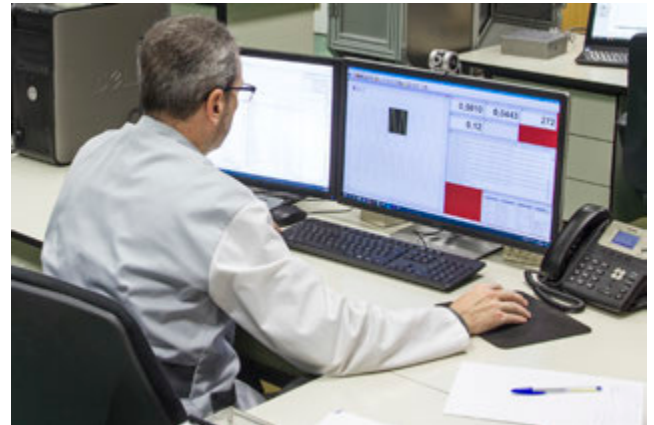

IBERTEST Spain - Madrid Technical Services



Real time TELEDIAGNOSIS link

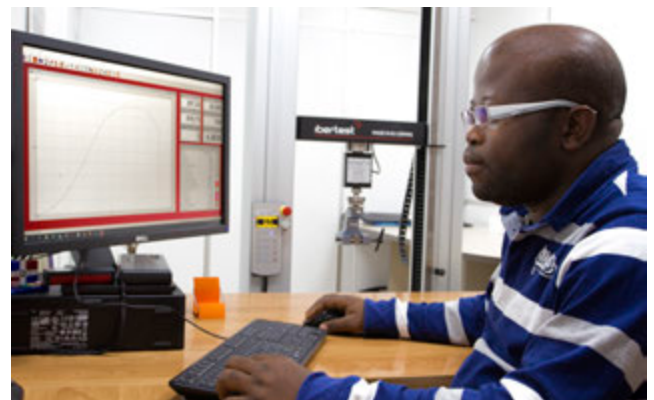

End-user laboratory (anywhere in the world)

Remote diagnostic service by TELEDIAGNOSIS is free during the first year and during the warranty period.

After the guarantee period, many of our customers require the Annual Telediagnosis Pass, which covers interventions of up to 5 hours a year.

V-2016-1-EN



c/ Ramón y Cajal, 18-20
28814 Daganzo de Arriba
Madrid - España

Tel. +34 918 845 385
Fax. +34 918 845 002
E-mail: info@ibertest.es

www.ibertest.com

S.A.E. Ibertest se reserva el derecho a realizar cambios técnicos o estéticos en la presente información técnica, sin previo aviso